

# Twice the Power at Double the Efficiency: Providing Secure Energy in Texas With CHP

Prepared by the

**Texas Combined Heat and Power Initiative**

February 2007



Contact: Rich Herweck  
Executive Director  
[www.texaschpi.org](http://www.texaschpi.org)  
(972) 979-4737  
[RichHerweck@sienergy.com](mailto:RichHerweck@sienergy.com)

# Twice the Power at Double the Efficiency: Providing Secure Energy in Texas with CHP

Prepared by the  
Texas Combined Heat and Power Initiative  
February 2007

## EXECUTIVE SUMMARY

Texas has long been a place where self-reliance is a defining characteristic. Yesterday's cowboys have been replaced by gritty business owners that create the jobs and produce the goods in our robust economy. Today, when our modern economy depends on instantaneous communications and non-stop 24/7 production, many savvy engineers and business owners have determined that self-reliance in energy production is SMART business.

There is something powerful about an electric generator that is perfectly integrated into your business operations. Powerful, efficient, and reliable, on-site power generation serves the needs of Texas business and it is an "engine" for jobs across Texas. "Combined heat and power" or "CHP" sounds new, but it's as old as the electric power grid in Texas. With over 16,000 MW of CHP now in use in the state, Texas is the nation's leader in CHP or "cogeneration" output. Everyday, cost effective, clean, energy efficient CHP powers up about 20% of the state's electricity grid and saves Texans millions of dollars annually.

CHP involves the simultaneous production and economical use of both heat and electric power. While all power generation creates heat, only CHP facilities capture and use the heat for important needs like steam and chilled water production. CHP facilities recover much of the heat wasted in central station generation, and that **DOUBLES** the efficiency of electric generation. Given the amount of CHP in Texas, a huge amount of energy savings has already been achieved. Heat recovery through CHP produces more energy efficiency by far than by any other means.

The high efficiency of CHP saves huge amounts of fuel. This in turn reduces NOx emissions and water consumption. Furthermore, clean burning renewable fuels and natural gas are the preferred fuels for CHP, which results in even greater emission reductions compared to the electric utility. CHP is good for renewable energy, it's good for natural gas, it's good for clean air, it's good for saving water, and it's good for Texas.

CHP plants are located at commercial and industrial facilities that use thermal energy, which is just about every facility across the state. While long hours of operation and low swings in energy consumption help the economics, a wide range of facilities located all across the state are candidates for CHP. In the case of petrochemical plants and other industrials, CHP systems can be very large (hundreds of megawatts), or in the case of the local grocery store, nicely packaged systems are available in small sizes down to a few dozen kilowatts.

Today, a large percentage of the 16,000 MW of CHP in Texas is at large industrial facilities. By adopting the recommendations suggested here, over the next 5 to 10 years, Texas has the potential to add another 11,000 MW at industrial facilities, and another 9,000 MW of CHP at smaller facilities such as hospitals, universities and schools, hotels, office buildings, food processing plants, manufacturers, farms, and wastewater treatment facilities. With about

20,000 MW of economically attractive, clean energy available through CHP, Texas businesses can meet the challenges of the future with this clean, reliable, and efficient energy source.

To encourage Texas businesses to learn about and implement CHP at their facilities, especially among the smaller facilities that have been slow to adopt, the Texas Combined Heat and Power Initiative recommends several policy changes:

- Develop a Standard Permit for air emissions specific to CHP projects that encourages emission reduction based on comparison to existing and proposed generation.
- Develop a Resource Portfolio Standard (RPS) for CHP.
- Promote CHP through the Energy Efficiency program that is supervised by the Public Utility Commission of Texas.
- Provide State support for the Houston Advanced Research Center to continue and to expand its statewide CHP education and outreach program.
- Encourage CHP facilities that serve multiple parties by allowing distribution of electricity directly to facilities receiving thermal energy from a CHP facility.
- Establish a revolving fund and a mandate to apply CHP at state and special district buildings.
- Develop policies that encourage the participation of small generators in the ERCOT wholesale power market.
- Encourage CHP in the portions of Texas outside of ERCOT by providing access to the Transmission and Distribution System and prohibit utilities from engaging in anti-competitive practices.

So much good is already provided by CHP in Texas that we “take it for granted”. The 16,000 MW that already generates power at industrial sites, hospitals, universities, and business establishments is a clean and quiet provider of value and energy savings. It is time for Texas to double the benefits of CHP by redoubling its efforts to educate Texas and expand the opportunities for CHP in the industries and businesses that drive our economy.

## **INTRODUCTION**

Combined Heat and Power (CHP) refers to the use of any of a number of technologies to capture and productively use the thermal energy that is naturally produced during power generation. A central feature of CHP is its location near to a facility with a thermal load, which allows for effective use of the heat. Today, many CHP plants are designed to first meet a facility’s thermal needs, and to produce electricity in the process. In some sense, thinking of CHP as a “boiler that produces waste electricity” is more accurate than thinking of it as an “electric generator that produces waste heat.”

Central station power generation preferred by some electric utilities is based upon inefficient steam generation, where economy of scale is used to make up for dismal energy performance. The typical power plants built by electric utilities in Texas are steam plants that are 25 to 35% efficient (proposed coal plants are also in this range); meaning only about 30%

of heat content of fuel is converted to power. The balance is released to atmosphere by evaporating water or through the exhaust gases. CHP systems, which can be as high as 70% to 80% efficient, are a major energy conservation technique even compared to a modern natural gas combined cycle power plant that operates at about 50% efficient.

Unlike large central station generators, CHP plants are often sized to meet the host facility's thermal loads. As a result, they are designed to integrate into a facility for maximum benefit. To further understand the concept of CHP, consider one of its simplest examples – the automobile. During cold weather heat from the engine cooling system is directed into the passenger compartment to heat the car without using any additional fuel. Imagine an engine driving an electric generator and all of the heat that normally would go to the radiator as well as heat from the exhaust is used for heating.

Widespread implementation of CHP in Texas will have dramatic energy efficiency and air quality benefits in addition to improving the reliability of energy supply, reducing load on the transmission and distribution system, and spurring economic development. This will benefit all energy consumers and the public.

## **HOW CAN CHP BE USED?**

CHP can be used any place that heat or cooling is needed. The systems can be very large to serve the heat load at a petroleum refinery or petrochemical complex, or small to match the heat load of a building, hospital, university campus, or school. The Appendix provides more application examples and links to additional information. CHP can use any fuel type including natural gas, biofuels, byproducts of agriculture and manufacturing, waste heat from manufacturing processes, and methane gas produced from landfills and anaerobic digesters.

A variety of proven, reliable technologies are available to match any application. These include gas engines, gas turbines, steam turbines, and heat recovery systems. Although highly proven, the technologies are constantly improving and new “packaged” products are becoming more readily available to serve additional applications. The Appendix also has more information about CHP technologies.

## **CHP IN TEXAS**

Texas has a long and successful history of CHP implementation. About 20% of the nation's CHP capacity, some 16,000 MW of electrical generating capacity, represents 16% of total generating capacity in Texas. Although some CHP capacity is many decades old, most of the capacity has been installed over the last 20 to 25 years.

As illustrated in the Chart below, most of the existing CHP capacity is provided by large plants. Only 2,500 MW of 16,000 MW is from plants with a capacity of less than 100 MW. Only 5 MW of the total CHP capacity is from plants smaller than 1 MW.

Gas turbines are the primary power source for over 90% of the capacity; about 16% of the capacity uses gas turbines only and almost 80% of the capacity uses a combined cycle of gas turbine with heat recovery and steam turbine.

### Existing CHP in Texas, Cumulative Capacity

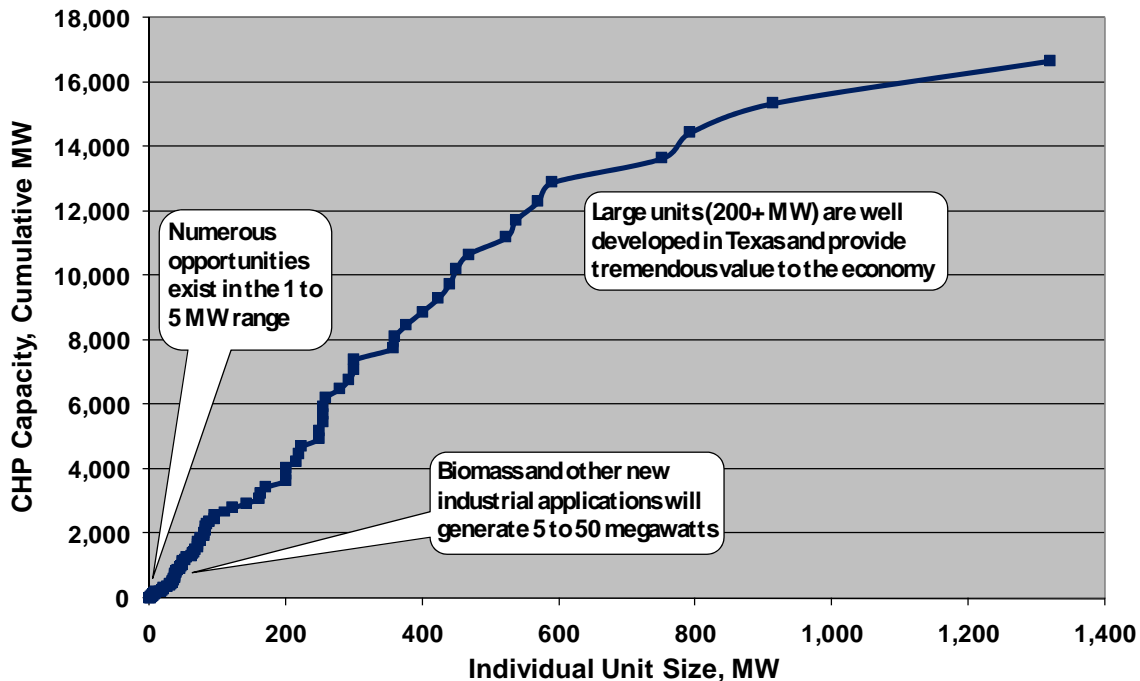

The majority of CHP systems in Texas use natural gas as indicated by the chart below. Although natural gas has become more expensive, the efficiency of CHP makes it a competitive fuel for electricity generation which benefits the natural gas industry and the state. Although biomass facilities represent a small fraction of CHP in Texas, there is potential for substantial growth.

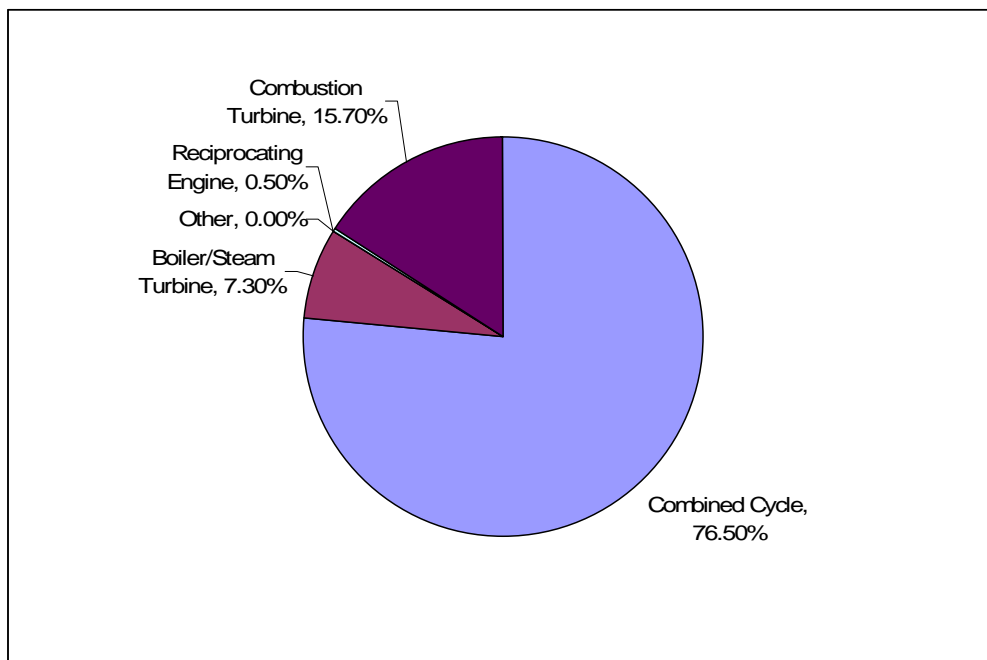

CHP can fulfill a vital need in the state's economy for highly efficient, highly reliable source for clean energy. A number of policy actions are available to the Texas Legislature to ensure continued adoption and use of CHP technologies.

**Texas CHP Fuel Mix**

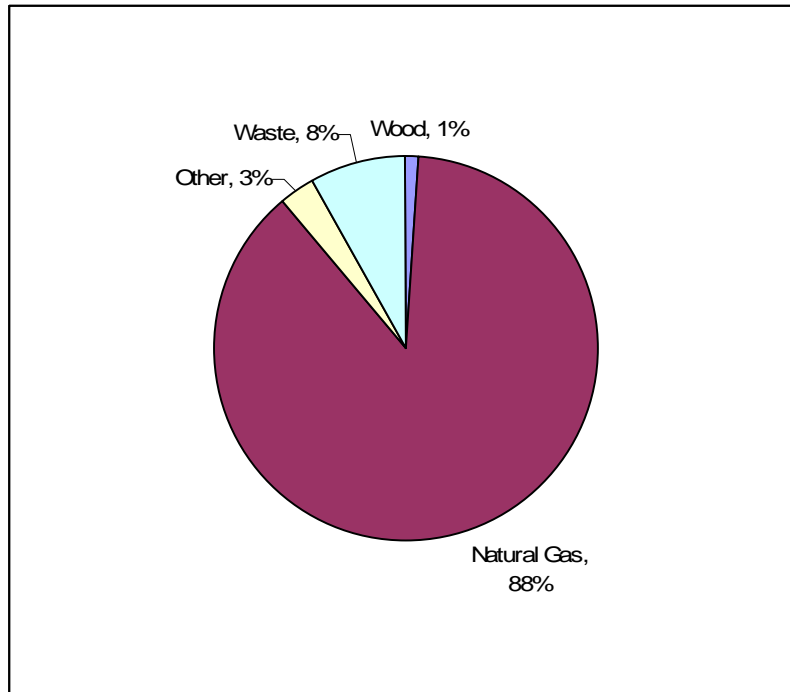

**ENERGY & ENVIRONMENTAL BENEFITS**

CHP is an important energy conservation technique. The addition of 5,000 MW of CHP capacity in Texas would save the equivalent of 185 BCF of natural gas or 34 million barrels of oil each year.

CHP reduces air emissions. The United States DOE and EPA estimated the emissions from a mix of small to medium sized natural gas CHP applications that are typical of commercial and small industrial applications and found that CHP units reduce NO<sub>x</sub> emissions by 84% compared to the average power plant emissions in Texas. Carbon dioxide is reduced by 51%. Sulfur oxides are reduced by 106%, which is to say that CHP not only reduces SO<sub>x</sub> emissions directly, but also eliminates some SO<sub>x</sub> associated with old, inefficient boilers.

CHP conserves water because the heat sink for CHP is useful thermal energy, not the evaporation of precious water resources. The typical CHP application does not increase the use of water. By comparison, a conventional 800 MW coal fired generating unit consumes enough water to supply the needs of over 300,000 citizens.

CHP facilities are integrated into existing industrial and commercial locations, which minimize land use issues.

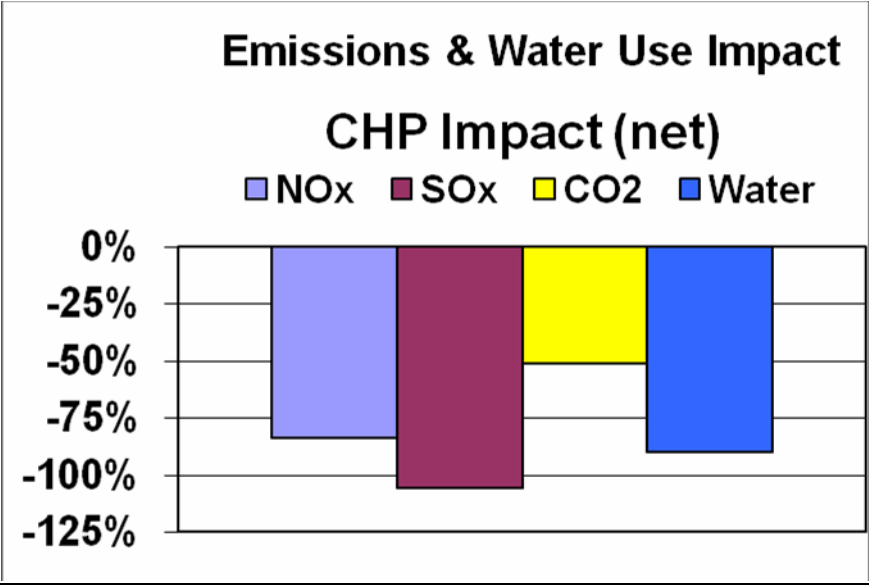

**ECONOMIC BENEFITS**

CHP reduces energy costs and makes Texas businesses more competitive in global markets. Facilitating small CHP applications will provide economic benefits for communities statewide. Installation of CHP systems create good paying jobs for Texans who design, construct, manufacture, and operate them. Because of the CHP potential in Texas and our leadership in the energy industry, our businesses are leaders in the supply of equipment and services for CHP systems. There are numerous facilities that supply and service turbo machinery, engines, and heat recovery systems throughout the state. In addition, Texas has a large number of consultants, engineers, and developers with experience in CHP. CHP adds value by utilizing existing infrastructure which also expedites the projects. CHP benefits the natural gas industry because it provides a way for natural gas to be competitive as a base load power resource.

**RELIABILITY BENEFITS**

CHP serves as an on-site power source to keep critical facilities ranging from hospitals to petroleum refineries running during grid outages. Whether power outages are brought by hurricanes, such as Rita, or black outs like the Northeast experienced in 2003, Texas must act now to ensure power continuity to the state’s critical infrastructure. CHP provides on-site or near-site power generation and thermal energy capture to ensure that vital institutions, such as hospitals, schools, and critical government offices can always operate, no matter the circumstances.

The reliability benefits are also proven at industrial sites such as refining and petrochemical facilities. Even a momentary power interruption can result in major consequences including upset emissions, equipment damage and lost production. Facilities that have invested in sufficient CHP capacity to supply the site have dramatically reduced outages from power failure.

CHP facilities are diverse and located near load reducing the load on the electrical grid. This increases the reliability of the grid, particularly at peak.

### **The Tale of Two Hospitals**

The reliability benefits of CHP are no better demonstrated than through the stories of Memorial Hermann Baptist Hospital in Beaumont, TX and Mississippi Baptist Hospital in Jackson, MS. In the days before Rita made landfall, Memorial Hermann patients were pre-evacuated to other facilities and the hospital was closed. When the storm made landfall, the hospital's backup generators started up but were unable to power the hospital's chillers and ceased operating before electric service from the utility grid could be delivered. As a result, the hospital was unable to provide services during the storm and remained closed for one week. The hospital incurred \$30 million in hurricane damages primarily related to loss of its HVAC systems. In contrast, Mississippi Baptist had installed a CHP system as backup power and was the only hospital in the Jackson area able to operate at nearly 100% after Katrina. For 52 hours, the hospital ran solely off its CHP system and was able to treat a large volume of patients and provide clothing, food and shelter to storm victims during the first night.



Memorial Hermann Baptist Hospital



Mississippi Baptist Hospital

## **RENEWABLE RESOURCES**

As noted in the chart detailing the fuel mix used in CHP, only a small fraction of CHP in Texas uses renewable fuel. The potential exists for much more. Sources of biomass fuel include urban wood waste, land clearing, agriculture waste, forestry waste, and wastes from lumber mills and paper mills. CHP enhances the benefits of renewable resources because it extends the environmental benefit from the resource and adds more value. Renewable generation is generally less efficient than fossil fuel generation which means that there is more benefit from CHP because there is more waste heat available.

As an example of the benefit of biomass fueled CHP, consider a CHP system at an ethanol plant using biomass from either waste by-products or other sources. The CHP system can be integrated with the VOC emission control system to further reduce energy use. Ethanol production becomes more energy efficient increasing the ratio of energy output to fossil energy input.

Current rules can discourage CHP using renewable resources. Power generation from renewable sources is eligible for Renewable Energy Credits (REC); but if steam is extracted from the steam turbine for heat energy, power output (and thus REC) is reduced although overall plant efficiency is higher and more fossil fuel is replaced. Since there is no credit for thermal energy, there is a disincentive to do the right thing.

Renewable energy is a tremendous opportunity for forestry and agriculture in Texas, and is receiving strong encouragement from State programs. CHP has been widely applied to biomass energy systems in Texas, particularly in the forest products industry. By encouraging CHP in the growing Renewable energy industry, all Texans receive enhanced economic and environmental benefits.

## **POTENTIAL FOR CHP DEVELOPMENT**

With over 98% of the CHP in the region existing at industrial sites, a conclusion can be drawn that highly sophisticated energy managers running the region's chemical plants and petroleum refineries recognize that CHP is cost-effective and beneficial. Even with that great success story, an estimated 11 GW of new CHP could still be implemented at industrial facilities in the region.

A tremendous opportunity for new CHP exists among medium-sized industry and commercial operations, which have not yet taken advantage of CHP like their larger scale counterparts. An estimated 9 GW of CHP potential exists in Texas at universities and schools, food processing plants, manufacturers, hotels, office buildings, farms, and wastewater treatment facilities.

## **HOW CAN TEXAS ENCOURAGE GREATER ADOPTION OF CHP?**

The following actions will encourage greater interest, understanding, and adoption of this vital energy resource.

### **Enhance Emissions Regulations to Capture the Full Benefits of CHP**

The Texas Commission on Environmental Quality (TCEQ) has a standard permit rule to expedite permitting for projects that improve the environment. The rule has been very successful in expediting projects that benefit the environment, and could be of great benefit to CHP projects. Presently the Standard Permit for electric generators discourages all but the very largest CHP projects. The Standard Permit for electric generators uses the concept of "output based NOx emissions" which partially recognizes the benefits of CHP, but the rule also has overly restrictive NOx emission limits for small electric generators. As most CHP projects are intended to first supply the host facility's thermal needs and are not sized to supply electricity to the wholesale electricity market, CHP technologies are NOT equivalent to electric utility generators and they should NOT necessarily be regulated as electrical generators. The current rule requires any electric generator in East Texas (generally East of the I-35/I-37 corridor) and electric generators greater than 10 MW anywhere in Texas to produce no more 0.14 lb of NOx per kWh, which is based on the most efficient large natural gas combined cycle power plant equipped with selective catalytic reduction (SCR). Credit is given for the usable heat recovered, but the benefit is undervalued by the assumption of 100% conversion of fuel to heat in a direct fired boiler or heater. SCR is a technology that is most effective for treating power plant exhaust that has a high concentration of NOx, such as a coal plant. It has been applied to a number (but not all) of the very large natural gas

combined cycle power plants in Texas, particularly in the non-attainment areas. It is not a cost effective way to reduce NOx from smaller systems. Since most CHP opportunities are for smaller systems, the rule arbitrarily imposes costs that prevent the project from being economic. The Permit by Rule (PBR) for new small boilers allows 3 times the credit provided for usable heat recovered by the Standard Permit for electrical generators. The PBR for engines and gas turbines in any services other than electrical generation allows for NOx emissions 40 to 60 times higher.

The Texas CHP Initiative supports TCEQ's goals to reduce NOx in Houston-Galveston and other areas of East Texas. It also supports a Standard Permit using "output based NOx emissions." However, the standard permit for electricity generators is actually counter-productive, because it inhibits cleaner CHP relative to less efficient existing and proposed central station power plants which emit more of ALL air pollutants including NOx, SOx, CO2, and mercury. Texas CHP Initiative believes that CHP systems are a technology class unto themselves and require a unique permit level that takes into account the unique features and benefits of these systems.

### ***Recommendation***

*The Texas CHP Initiative recommends that a output based Standard Permit be developed for application to CHP projects that is size, technology, and region specific; recognizes the full amount credit for reducing thermal energy, and encourages emission reduction based on comparison to actual existing and proposed generation.*

### **Create a Resource Portfolio Standard Requiring Additional Use of CHP**

CHP systems are highly efficient and produce very low emissions relative to alternative technologies. The potential market size for CHP is very large and these projects can be developed quickly, cost effectively, and in sufficient quantity to dramatically impact ERCOT reserve margins. The Texas CHP Initiative estimates that 6-8 GW of new CHP capacity can be successfully developed in the next ten years.

Electric utilities of all types and in all states have been traditionally hostile to CHP because it encroaches on their monopoly, and they have a number of effective tactics to stop CHP projects in their tracks. These tactics include the use of predatory rates, punitive standby charges, and onerous interconnection requirements. Electric utilities in the regulated parts of Texas continue to use these tactics to thwart CHP. Even within the deregulated areas of ERCOT, the T&D companies may view CHP as a negative for fear it may reduce their revenues. Other market participants including REPs and GENCOs have no incentive to support CHP. The long tradition of these practices has made managers of enterprises that would benefit from CHP ambivalent and unwilling to pursue the opportunity.

Texas residents and power consumers have an interest in securing a diversified portfolio of clean, reliable, and efficient energy technologies. When markets fail to deliver useful and desirable solutions, the Legislature should step in to promote their use. As was proven with the highly successful Renewable Portfolio Standard implemented in 1999 and as amended in 2005, this market-based approach can create positive impacts. Additional use of CHP technologies can be achieved by implementing a Resource Portfolio Standard for CHP requiring a certain portion of retail electricity sales to be from qualified CHP facilities.

### ***Recommendation***

*The Texas CHP Initiative recommends the Legislature create a Resource Portfolio Standard for CHP (CHP-RPS) modeled on the successful Renewable Portfolio Standard, which successfully stimulated market demand for renewable energy beginning with its implementation in 1999. As Texas already has about 16,000 MW of CHP, a CHP-RPS should require an additional 5,000 MW of CHP by 2016. To address ERCOT reserve margin requirements and reliability needs, the CHP-RPS should be set to 21,000 MW by 2016, with that goal comprised of the sum of approximately 16,000 MW of existing CHP capacity, plus 5000 MW of new CHP capacity. Renewable Energy Credits (REC) should be output based with credit given to thermal output in CHP applications using a renewable fuel.*

### **Provide financial incentives to CHP adopters**

Each hour of the day, central station electric generation wastes 2/3 of the energy consumed in the form of unused heat exhausted into the environment. Not only does this waste produce much unwanted pollution, such as NO<sub>x</sub> and CO<sub>2</sub>, it also wastes precious natural resources, which drives up the cost of energy for all Texas energy consumers. CHP IS ENERGY EFFICIENCY that can dramatically reduce energy consumption, provide dispatchable electrical generation for peak loads, and shift peak air conditioning off the electrical grid.

For Texans to achieve the full benefits associated with CHP (lower cost of fuel, cleaner air, diversified resources, job creation, and greater energy security), financial incentives are important drivers for early adoption. Unlike electric utilities, which have a long financial time horizon, facility managers thinking about CHP require these systems to exceed aggressive financial hurdles, with simple payback periods of 1 to 3 years being common. Private organizations are not willing or capable of paying for public goods.

Energy efficiency is recognized as the least expensive and cleanest energy resource, yet many markets are notoriously unwilling to invest in it. Texas has long recognized the need to support energy efficiency with the creation of a standard offer program to provide direct financial incentives for energy and capacity savings, and these incentives have been extremely effective in promoting energy efficiency adoption. In EPACT05, the federal government also offered tax incentives for adopters of certain energy efficiency technologies.

In Texas, the current standard offer program has insufficient funds to meet the existing market demand for energy efficiency. CHP may be the largest opportunity to promote energy efficiency in the state, but it is specifically excluded in the PUC Energy Efficiency Rule even though CHP meets all three criteria in PURA Sec. 39.905(a)(2).

*“all customers, in all customer classes, have a choice of and access to energy efficiency alternatives and other choices from the market that allow each customer to reduce energy consumption, peak demand, or energy costs”*

Greater emphasis on energy efficiency, including CHP, could go along way toward addressing the state’s pressing energy needs.

### ***Recommendation***

*The Texas CHP Initiative recommends the Legislature increase funding for utility standard offer program promoting energy efficiency and require the Public Utility Commission to explicitly include CHP as an allowed energy efficiency measure suitable for standard offer incentives.*

### **Expand CHP Education and Outreach Efforts to Potential Adopters**

Outreach programs to educate facility managers and owners about CHP systems are essential to promote technology adoption, especially in the commercial and institutional markets where CHP technology adoption has been slow. Outside of the petrochemical industries, where knowledge of CHP tends to be better, facility managers and owners need additional information regarding the value and benefits of CHP. Implementation of CHP systems is rare in commercial and institutional settings, because technical staff has limited knowledge regarding technologies, costs, reliability, and analysis techniques needed to evaluate CHP.

An existing education and outreach program has been highly effective in raising awareness of CHP and providing services to potential adopters. Over the last three years, the U.S. Department of Energy has funded the Gulf Coast Combined Heat and Power Application Center to provide information and technical support regarding CHP to facility managers, building owners, engineers, architects, and other potential adopters. Located at the Houston Advanced Research Center, which is a non-profit scientific research center active in state air quality initiatives and other environmental issues, the Application Center hosts technical workshops related to CHP, and provides feasibility assessments and general project development assistance to potential adopters. Because the Application Center has no financial interest in potential developments, facility managers can find unbiased information to promote effective learning and decision making. Over the last two years, federal funding for the Application Center has dropped precipitously, so additional funding is needed to continue and to expand the program.

### ***Recommendation***

*The Texas CHP Initiative recommends the Legislature provide \$500,000 per year over the next two years to the Houston Advanced Research Center to continue and to expand its statewide CHP education and outreach program.*

### **Encourage multi-party CHP projects**

CHP projects involve the cogeneration of thermal energy and electricity. Through the effective use of all heat and electricity produced from the process, CHP can provide very high energy efficiency, and hence low cost energy supplies to industry. Low cost energy supplies are paramount to many industries in Texas, with jobs and economic development hanging in the balance.

As a rule of thumb, CHP projects turn one unit of energy into about two-thirds thermal energy and one-third electricity. The energy use at any one facility may not support an

optimal CHP configuration. As a result, CHP developers often work with adjacent facilities to optimize CHP configuration by better balance of the electrical and thermal load and improving the economy of scale of the project. Working with multiple entities is not a problem for thermal energy distribution, as a steam or chilled water pipe can run between the two properties. However, current laws regarding electricity prohibit distributing electrical energy between facilities on private lines. Electricity can go into the ERCOT grid for distribution next door, but this solution requires additional expenses to transform voltages appropriately, and necessitates added costs for wholesale market rules, wholesale power pricing, and power wheeling.

***Recommendation***

*The Texas CHP Initiative recommends the Legislature allow distribution of electricity directly to facilities receiving thermal energy from a CHP facility.*

**Mandate and finance CHP at State facilities**

Many state and special district buildings could benefit from CHP including hospitals, correctional institutions, buildings, schools and universities. The capital cost of CHP projects can be financed by long term at favorable interest rates and be repaid with energy savings.

***Recommendation***

*The Texas CHP Initiative recommends the Legislature establish a revolving fund and a mandate to apply CHP at state and special district buildings.*

**Encourage the participation of small electrical generators as resources in the ERCOT market.**

Increased penetration of CHP in the Texas market, especially smaller CHP systems sized appropriately for the commercial and institutional building market, will result in greater opportunities to use these resources in the wholesale electricity market. As a result of improved emergency preparedness programs, political subdivisions have installed systems that can also be considered as resources. The Electric Reliability Council of Texas' treatment of small capacity resources – demand response (changes to load) and distributed generation (dispatch of resources located on the customer's premises) – is inadequately addressed. ERCOT's current system hardware, architecture and coding and storage space can not fully accommodate these loads. As the number of these resources increases, ERCOT needs a market platform that accommodates the participation of all resources, including some CHP, so these resources can actively participate and contribute to the Texas wholesale electricity market.

***Recommendation***

*The Texas CHP Initiative recommends the Legislature require the Public Utility Commission and the Electric Reliability Council of Texas to do a cost benefit analysis that considers the capabilities of numerous, small electrical generators to provide needed capacity and energy to the Texas electricity grid.*

**Encourage CHP outside of ERCOT with access to the transmission and distribution (T&D) system and prohibit utilities from engaging in anti-competitive practices.**

Electric utilities of all types and in all states have been traditionally hostile to CHP because it encroaches on their monopoly. Even after passage of PURPA in 1978, utilities used a number of tactics to delay or stop CHP projects including the use of predatory bilateral “economic development” or “cogen killer” rates, punitive standby charges, onerous interconnection requirements, and their substantial market power. These tactics continue to be practiced in the regulated areas of the state. With the timing of deregulation uncertain, immediate action is needed to assure development of fair rates for transfer of power, backup and supplemental power, and prohibit predatory rates.

***Recommendation***

*The Texas CHP Initiative recommends the Legislature and the Public Utility Commission assure that policies fair to CHP and renewable energy facilities for wheeling and backup power rates and interconnections be followed by utilities outside of ERCOT, and that all utilities without open access be prohibited from using monopolistic practices to stop CHP projects.*

## APPENDIX

### CHP Technologies

#### Reciprocating Engines

Reciprocating or piston-driven engines were developed over 100 years ago. The technology has improved dramatically over the past three decades due to increased environmental and economic pressures, and the need for power density improvements. These engines offer a lower capital cost (particularly for small projects) CHP alternative that is easy to startup, reliable, offers good load-following characteristics, and excellent heat recovery potential. There are two basic types - spark ignition and compression ignition. The former uses natural gas as the preferred fuel, although other fuels like propane and gasoline can be used. The electric efficiency of natural gas fired engines range from 28% to 40% LHV based on size of the engine. The waste heat can be recovered in CHP mode to achieve an overall efficiency of 70% to 80%. The compression ignition type operates on diesel or heavy fuel and typically has efficiencies in range of 30% to 50% HHV.

Reciprocating engines tend to have higher emissions than other technologies. In some locations, especially where local air quality standards are high, emissions permits could limit engine use, although the use of exhaust catalysts and better combustion design and control has significantly reduced emissions for current technology.

The spark ignition engine operates on the principle of Otto cycle while the compression ignition engine operates on Diesel cycle. For the most part, these two cycles are identical except for the method of igniting the fuel. These engines use a cylindrical combustion chamber in which a close fitting piston travels the length of the cylinder. Complete cycle consists of intake stroke, compression stroke, power stroke, and exhaust stroke. The piston is connected to the crankshaft that transforms the linear motion to the rotary motion.

#### Gas Turbines

Gas turbines have been used to generate power for about 70 years. The technology revolutionized airplane propulsion industry in 1940s and is currently the economic and environmentally preferred choice for new power generation plants in the United States. Typically, gas turbines are in the 500 kW to 250 MW range. These turbines exhaust high quality heat that can be used in CHP mode to reach overall system efficiency of 70% to 80%. Gas turbines were typically used for by the utilities for peaking power capacity, although now high performance gas turbines are used in combination with steam turbines in a combined cycle plant with efficiencies approaching as high as 60% LHV. The simple cycle efficiency of gas turbines approaches 40% LHV.

Gas turbines operate on the principle of Brayton cycle. In this case, air is compressed in a compressor, heated in a fuel combustion chamber, and then expanded in a turbine (see figure below). The excess power produced by the turbine is used to drive the compressor. The power produced by the turbine and consumed by a compressor is proportional to the

absolute temperature of the gas passing through it and is limited by turbine materials. In general, use of high temperature and high pressure ratios results in higher efficiency and specific power.

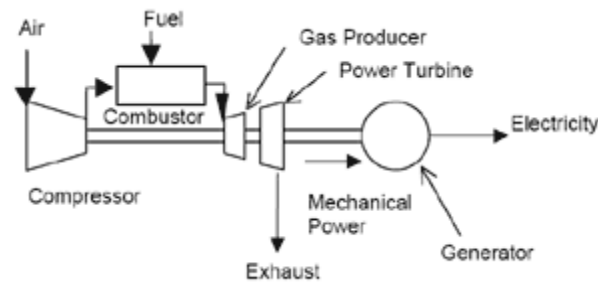

**Figure: Components of a simple cycle gas turbine**

Three different kinds of gas turbines are common. These include:

- **Frame gas turbines:** These are the industrial gas turbines for stationary power generation and are available in size range of 1 MW to 250 MW. These are less expensive, more rugged, and are suited for continuous base-load operation with longer inspection and maintenance intervals.
- **Mini and micro turbines:** Mini and micro turbines are the newer generation of smaller turbines. The capacities of mini turbines range from 100 kW to 1 MW and micro turbines range in capacities from 25 kW to 100 kW. It is not uncommon to ignore the differentiation between mini- and micro- turbines. For the purpose of discussion all turbines with capacity less than 1 MW will be referred to as microturbines. These turbines can use natural gas, propane, and gases produced from landfills, sewage treatment facilities, and animal waste processing plants as a primary fuel. The fuel source versatility of microturbines allows their application in remote areas.
- **Aeroderivative gas turbines:** These are typically used for jet and turboshaft aircraft engines, and are lightweight, thermally efficient, but expensive. For the stationary power generation, these turbines are typically operated at compression ratios of 30:1, therefore requiring high-pressure external gas compressor. These turbines are available in sizes typically less than 50 MW.

## Steam Turbines

Steam turbines have been used to generate power for about 100 years, and today, they generate most of the electricity produced in the United States. Typically, steam turbines are in the 50 MW to 500 MW range, and they are widely used in CHP applications. Conventional steam turbines have multiple stages to enhance system efficiency. The installation also requires a boiler to generate steam, fuel handling systems, and steam handling systems. The separation of boiler from the power generating equipment enables operation with wide range of fuels. Steam turbines are well suited to medium- and large-scale industrial and institutional applications where inexpensive fuels, such as coal, biomass, various solid wastes and byproducts (e.g., wood chips. etc.), refinery residual oil, and refinery

off gases are available. The electrical generating efficiency of standard steam turbine power plant varies from high of 40% HHV for large, electric utility plants designed for highest practical annual capacity factor, to under 10% HHV for small, simple plants which make electricity as a byproduct of delivering steam to processes or district heating systems.

Steam turbine operates on the principle of Rankine Cycle (see figure below). Water is first pumped to medium to high pressure. It is then heated to the boiling temperature corresponding to pressure, boiled, and most frequently superheated. The turbine expands the pressurized steam to lower pressure and the steam is exhausted either to a condenser at vacuum conditions or into an intermediate temperature steam distribution system that delivers the steam to the industrial or commercial application.

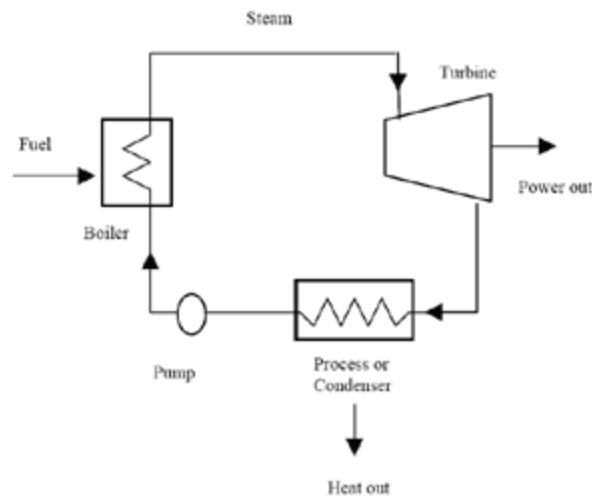

**Figure: Components of a Boiler/Steam Turbine**

Three different types of steam turbines are common. These include:

- **Condensing Steam Turbines:** These turbines exhaust directly to the condensers that maintain vacuum conditions at the discharge of the turbine. Typical use is at central power generation plants where maximum power and electrical generation efficiency is desired from steam supply and boiler fuel.
- **Back-pressure turbines:** These turbines are a non-condensing type, which means they exhaust the entire flow of steam to the industrial process or facility steam at conditions close to process heat requirements. The discharge pressure depends on the type of CHP application. Typical use is district heating systems and industrial processes.
- **Extraction turbines:** These turbines extract a portion of the steam at some intermediate pressure before condensing the remaining steam. The regulated extraction permits more steam to flow through the turbine to generate additional electricity during periods of low thermal demands.

## Thermal Energy

Efficient capture and effective use of thermal energy is critical to a successful CHP project, from both a technical and a financial perspective. In most CHP applications, the exhaust gas from the electric generation equipment is ducted to a heat exchanger to recover the thermal energy in the gas. Generally, these heat exchangers are air-to-water heat exchangers, where the exhaust gas flows over some form of tube and fin heat exchange surface and the heat from the exhaust gas is transferred to make hot water or steam. The heat is then used to provide hot water or steam heating and/or to operate thermally activated equipment, such as an absorption chiller for cooling or a desiccant dehumidifier for dehumidification.

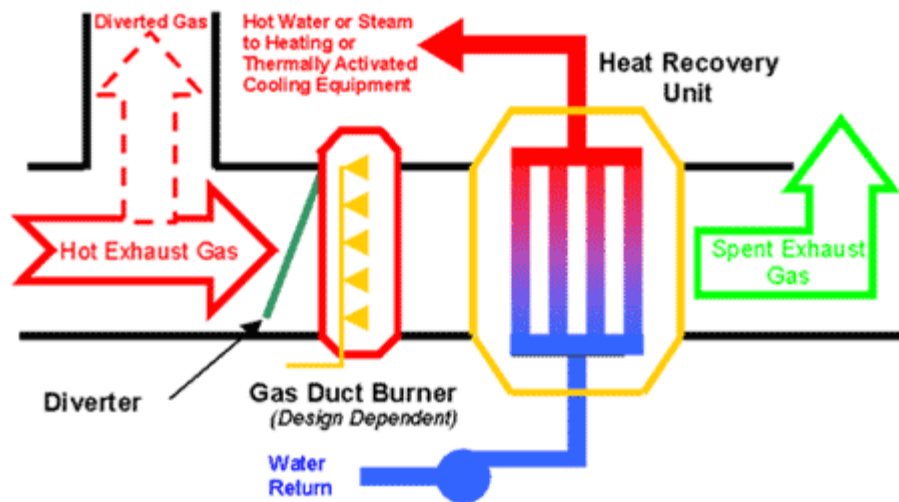

## Heat Recovery Steam Generators

Heat recovery steam generators (HRSGs) are essentially boilers that capture or recover the exhaust of a prime mover such as a combustion turbine, natural gas or diesel engine to create steam.

The system consists of a bank of tubes that is mounted in the exhaust stack. Exhaust gases at temperatures between 800 °F to 1200 °F heat these tubes. Water is then pumped and circulated through the tubes and can be held under high pressure to temperatures of 370 °F or higher resulting in the production of high pressure steam. Since the flue gas never comes in direct contact with the water, the steam can be safely used in thermally activated cooling equipment.

HRSGs, which range from 10 MW to 250 MW and have an efficiency of 60% to 85%, are typically found in many combined cycle power plants.

## Absorption Chillers

Absorption chillers use heat instead of mechanical energy to provide cooling without the use of ozone-depleting chlorofluorocarbons (CFCs). Unlike conventional electric chillers, which use mechanical energy in a vapor compression process to provide refrigeration, absorption

chillers primarily use heat energy with limited mechanical energy for pumping. These chillers can be powered by natural gas, steam, or waste heat.

An absorption chiller works by transferring its thermal energy from the heat source to the heat sink through an absorbent fluid and a refrigerant. The absorption chiller creates refrigeration by absorbing and then releasing water vapor into and out of a lithium bromide solution (figure below).

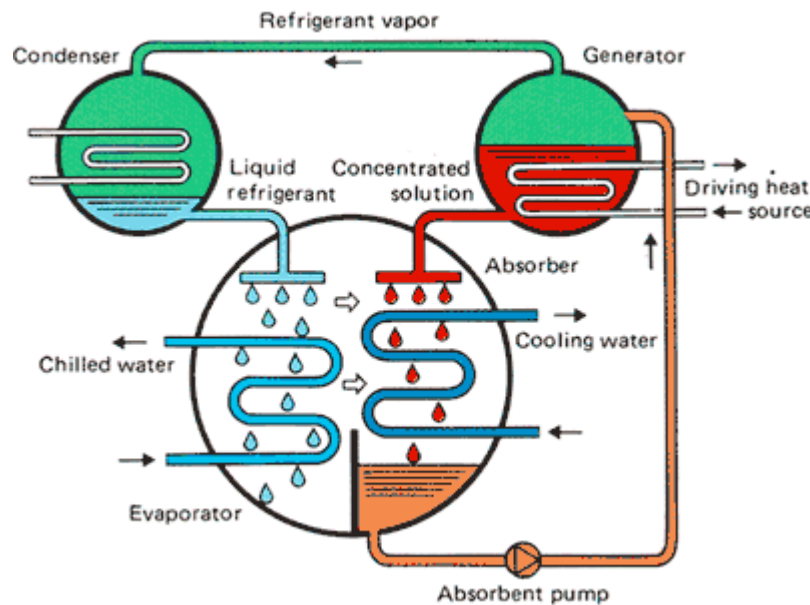

**Figure: Simplified absorption cycle**

Absorption chillers are available in two configurations: single-effect and double-effect. Double-effect machines are about 40% more efficient compared to single-effect chillers and require 45% less steam but at 10 to 15 times higher pressure.

Absorption chillers generally become economically attractive when there is a source of inexpensive thermal energy at temperatures between 212°F and 392°F. These chillers can change a building's thermal and electric profile by shifting cooling from an electric load to a thermal load. This shift can be very important for facilities with time-of-day electrical rates, high cooling season rates, and high-demand charges.

## Desiccant Dehumidifier

Desiccant materials can remove humidity from air, which reduces the amount of energy needed to air condition a space, and they can also improve indoor air quality. Space conditioning is comprised of two separate components:

- Sensible cooling - lowering the air temperature
- Latent cooling - reducing humidity in the air

By reducing the moisture content of the air, desiccants reduce the latent cooling load on conventional AC equipment. Thus, the chiller load is primarily limited to only the sensible

cooling (i.e., reducing the temperature). By dehumidifying the air, desiccants improve the efficiency of standard air conditioning equipment and thereby lower the cost for air conditioning. Controlling humidity (to less than 60%) helps prevent the growth of mold, bacteria, and microorganisms that cause allergies or are otherwise harmful to human health.

Desiccants use chemical (or physical) absorption of water vapor to hygroscopic materials. Heat is required to remove water from the desiccant, thereby regenerating it to be reused for further dehumidification. Thus, desiccants provide excellent heat loads for CHP systems throughout the cooling season.

## **CHP Applications**

### **Emergency Preparedness**

Effective emergency preparations and response depend entirely on the reliability and quality of a first responder's power supply. If primary grid power goes down, so too can "911" and state emergency communication centers, first responder stations, hospitals, prisons, control centers, traffic signals, public transportation, wastewater treatment facilities, water pumping stations and other critical infrastructure.

Typically facilities like hospitals have diesel generators on site for emergency power when the grid fails. Unfortunately, diesel generators have a history of failure in disaster situations including the July 1999 power outage in New York City and the massive Northeast blackout in August 2003. After Hurricane Katrina, downed power lines and flooding made it impossible to deliver diesel fuel to smaller generators that would ordinarily serve as backup power. Without electricity the Gulf Coast region was not able to function. Without power the emergency response system broke down.

Installing combined heat and power systems at critical facilities and emergency response centers could help prevent another Hurricane Katrina. The ability of a CHP system to generate both electricity and thermal energy for use in space heating/cooling, hot water and steam would allow hospitals to continue functioning, like Mississippi Baptist Medical Center (MBMC) in Jackson, MS - the only hospital in the Jackson area to continue operating at near capacity during and after Hurricane Katrina made landfall.

To learn more about how CHP can help protect your facility when natural or man-made disasters strike, please review the information at the Resource Directory at the link below. <http://www.gulfcoastchp.org/Markets/Emergency/>.

### **Hotels and Office Buildings**

The hotel industry is currently in an upswing. However, while revenues are increasing, costs are rising as well. Energy represents one of the few cost elements within a hotel's control.

Large hotels (i.e., those with 500 to 1,000 rooms or more) represent an important market segment. These huge facilities have more in common from an energy standpoint with a small university than with a small business hotel or roadside motel. They often include multiple restaurants, nightclubs, spas, health clubs, movie theaters, and shops. These facilities occupy

millions of square feet of building space, and their energy use intensity per square foot is much higher than that of a typical business hotel.

### **What can CHP do for Hotels?**

Combined heat and power can be an excellent solution for controlling energy costs while improving the reliability of power supply for your hotel. With CHP your hotel can:

- Reduce operating costs and control rising energy costs
- Ensure the availability of reliable hot water and electricity supply
- Increase energy efficiency and improvement environmental performance

### **Current Status**

Ninety-eight hotels in the United States currently have CHP systems, representing more than 63 MW of electricity capacity. Many of these systems were installed during the late 1980s and are continuing to operate reliably and efficiently today.<sup>1</sup> Texas is home to two such systems with a total capacity of 355 kW. One was installed at the Sheraton Hotel in Denton in 1988 and the other was installed at the Sheraton Hotel on South Padre Island in 1990. While unconfirmed, it is assumed that both of these systems are still in operation.

### **Future Potential**

The market analysis for hotels developed by the U.S. EPA's Combined Heat and Power Partnership shows that more than 9,000 of the nearly 48,000 hotels in the United States have energy characteristics suitable for current CHP technology. More than 1,000 of these sites are likely to meet a simple payback on their investment within 5 years or less.

The total economic potential for hotels in the U.S. is 1,456 MW.<sup>2</sup> In the Gulf Coast Region there is a total economic potential of **211 MW** divided between Louisiana (61 MW) and Texas (150 MW). The simple payback period for hotels with at least 1000 rooms is about 5 years or less in these two states.

The EPA ENERGY STAR website is good place begin research:

<http://www.energystar.gov/hospitality>.

### **Institutional Buildings**

CHP systems can help reduce the cost of heating, cooling, or providing power to a wide variety of government and institutional facilities. Installation of CHP systems at these facilities can provide increased power supply reliability, better occupant comfort, improved indoor air quality, and reduced boiler emissions. Major institutional users are colleges/university campuses, district energy/utility facilities, and hospital-type facilities. Medical care facilities average 3.75 MW capacity per site. Colleges/universities average about 12.5 MW per site. Primary schools, on the other hand, have numerous sites, but only average 135 kW per site. Institutional facilities have widely ranging energy needs that require



unique solutions appropriate for their specific situations. Because CHP technologies encompass a broad array of flexible and scalable technologies, in many cases a customized solution can be found to fit the exacting needs of institutional clients.

The following institutional sites could make excellent hosts for CHP installations:

- Hospitals & Healthcare Facilities

For more information on Universities see the following about Dell Children's Medical Center.

<http://files.harc.edu/Sites/GulfCoastCHP/CaseStudies/AustinTXChildrensMedicalCenter.pdf>

- Universities & Colleges

For more information on Universities see the following about The University of Texas adding 25 MW to their existing CHP capability.

<http://files.harc.edu/Sites/GulfCoastCHP/CaseStudies/AustinTXUTAustin.pdf>

- Government Buildings
- Wastewater Treatment
- Prisons
- District Energy

## Hospitals & Healthcare Facilities

Hospitals are excellent candidates for CHP systems because they have high electrical and thermal energy needs that generally follow each other and have significant energy demands 24/7/365. Many hospitals across the country are discovering the power of CHP for improving their bottom line and operational capabilities. More than 200 hospitals and healthcare facilities nationwide are using CHP to lower energy costs by up to 50% and decrease power outages and interruptions by up to 95%.

For more information on the Please [click here](#) ( 927 KB) to access the presentation materials used for the November 1, 2005 audioconference sponsored by THA.

## Petrochemicals

The petrochemical and refining market includes industries that refine petroleum, extract oil and gas, and manufacture chemical products. Refined products include fuels, such as gasoline and aviation fuel; non-fuel products, such as asphalt and wax; and feedstock for chemical plants. Manufactured chemical products include alkalies, chlorine, plastics, resins, carbon black, fertilizer and industrial gases among others [2].

For detailed profiles of individual sectors, see the EPA's industry profiles for [Inorganic Chemicals](#); [Organic Chemicals](#); [Oil and Gas Extraction](#); and [Petroleum Refining](#).

Additional information is available about the:

- [Current Status](#)

- [Future Potential](#)
- [Benefits, Challenges & Solutions](#)

### Issues

The Petrochemical and Refining Market is facing rising raw material and fuel costs, increasing competition from overseas and strict emissions and environmental standards for their facilities and for the products they produce. Power reliability is another important consideration

These industries continue to consolidate via mergers and acquisitions. Larger companies with vertically-integrated operations have tended to spin off portions of their downstream business, such as refineries and retail outlets, thereby forcing them to become independently profitable [3].

To cut costs and increase profits, the petrochemical and refining market is focusing on more lucrative product lines, improving process efficiencies, and carefully tracking energy use and expenditures [4].

### Market Characteristics

Typically, this market has:

- Long operating hours
- Large coincident electricity/thermal loads
- High thermal demands (process heating and cooling)
- Aging boiler and other equipment infrastructure
- High steam and electricity costs
- Life-cycle economic planning.

The petrochemical and refining market is ideally suited for CHP because of these characteristics. In fact, this market has the single largest installed CHP capacity [5]. It also has the largest future CHP potential. (For more on these topics see [Current Status](#) and [Future Potential](#).)

For a diagrammatic summary of this market's energy use and loss, please see the U.S. Department of Energy's [Chemicals Energy Footprint](#); [Petroleum Refining Energy Footprint](#).

Following is a link to the story of a CHP facility at a polymer plant.

[http://www.distributedenergy.com/de\\_0411\\_need.html](http://www.distributedenergy.com/de_0411_need.html)

### Medium Industrials

Following are links to specific CHP applications at medium industrial facilities:

- [Ethanol](#)
- [Food Processing](#)
- [Pharmaceuticals](#)
- [Pulp & Paper](#)

## **Agricultural Operations**

The agricultural sector provides significant CHP opportunities through waste management and opportunity fuels. Agricultural wastes or "energy crops" can be used to co-fire existing generators. Alternatively, animal and agricultural wastes can be converted to biogas through the process of anaerobic digestion. This process uses naturally occurring bacteria to decompose crop and animal wastes. Anaerobic digesters are sealed with covers that trap the biogas produced in the digester. The biogas can then be used in conventional engines or micro-turbines to produce electricity and heat for the farm. Thermal needs include hot water, space heating, and heat to maintain the temperature of the anaerobic digester.

The following agricultural sites make excellent hosts for CHP installations:

- Feedlots
- Dairy farms

For information on CHP at dairies in Vermont see the following:

<http://www.cvps.com/cowpower/>

<http://www.epa.gov/CHP/funding/cenvtbiomasselectricityproduct.htm>

- Timber and forest operations
- Rice, cotton, sugar cane, and sugar beet processing operations

For more information on Agriculture applications see the Resource Directory at the link below.

<http://www.gulfcoastchp.org/Markets/Emerging/Agricultural>

## **Residential (Micro-CHP)**

Small power generators like micro-turbines, Stirling engines, and fuel cells are potential technologies to provide CHP for residential applications. Micro-CHP systems generate 1-25 kW of electricity, while the waste heat is used for air conditioning, water heating, space heating, swimming pool heating, or dehumidification. On-site power generation can dramatically increase the fuel efficiency of the home, while increasing power quality and reliability during severe weather conditions. Today, the initial cost to implement systems is a substantial barrier and few installations have demonstrated the concept. Field trials of residential systems are being undertaken now, which could help to drive the introduction of commercial systems on a large scale in the next five years. For more information on Residential applications see the Resource Directory at the link below.

<http://www.gulfcoastchp.org/Markets/Emerging/Residential>